

TY-D

台湯動力股份有限公司

TY DYNAMIC CO., LTD.

磷酸鋰鐵電池

LiFePO₄ Battery

TYD30-330

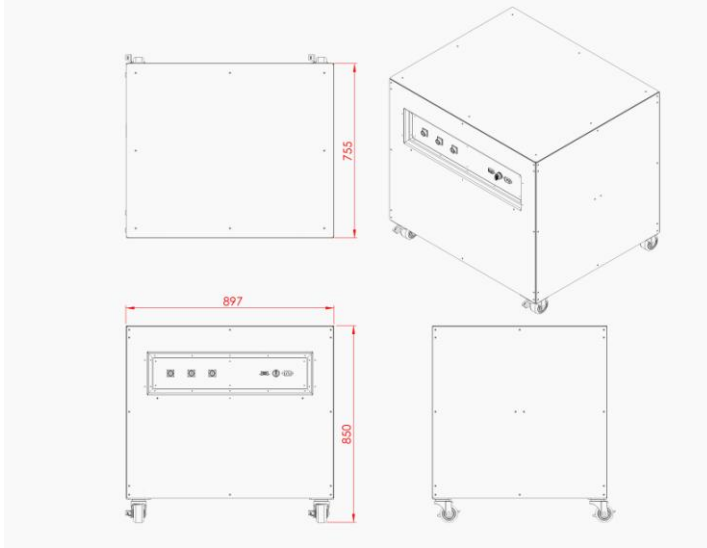

機械特性 Physical Characteristics

型號 Model	TYD30-330
長度 Length	897 mm
寬度 Width	755 mm
高度 Height	850 mm
重量 Weight	Approx. 200 kg
電槽材質 Housing Material	SUS

電氣特性 Electrical Characteristics

公稱電壓 Nominal Voltage	330 V
公稱容量 Nominal Capacity	30 Ah
內阻 AC IR(1kHz)	<120 mΩ
瓦時 Watt-Hours(0.5C,25°C)	10 kWh
循環壽命 Cycle Life at DOD 100% (25 °C)	
1C Discharge/0.5C Charge(80% ↑)	1400 Cycles

操作狀態 Operating Conditions

充電狀態 Charge Conditions :	
標準充電 Standard Charge	CC/CV
標準充電電壓 Standard Charge Voltage	365 V
標準充電電流 Standard Charge Current	15 A
放電狀態 Discharge Conditions :	
最大持續放電電流 Max. Discharge Current(continuous)	60 A
最大瞬間放電電流 Max. Discharge Current(10ms)	120 A
放電截止電壓 Discharge cut-off Voltage	260V
操作溫度範圍 Operating Temperature Range :	
充電溫度 Charge Temperature	-10 °C / 45 °C
放電溫度 Discharge Temperature	-10 °C / 45 °C
儲存溫度 Storage Temperature	-10 °C / 45 °C

用途 Application:

移動式儲能系統 Mobile Storage System ◦

備註 Remark : 使用條件超出上述規格，請與我司聯絡 Please feel free to contact us if you have any specific requirements.

TYD30-330 溫度特性 Discharge Temperature Characteristics – Amp-Hours(%)

Temp. \ Current	0.5C	1C	2C	3C
-10 °C	90%	86%	87%	90%
0 °C	96%	94%	93%	94%
10 °C	99%	99%	98%	98%
25 °C	100%	99%	99%	
45 °C	99%	99%	98%	97%

1. 放電特性 Rate Discharge Curve according to Ambient Temperature

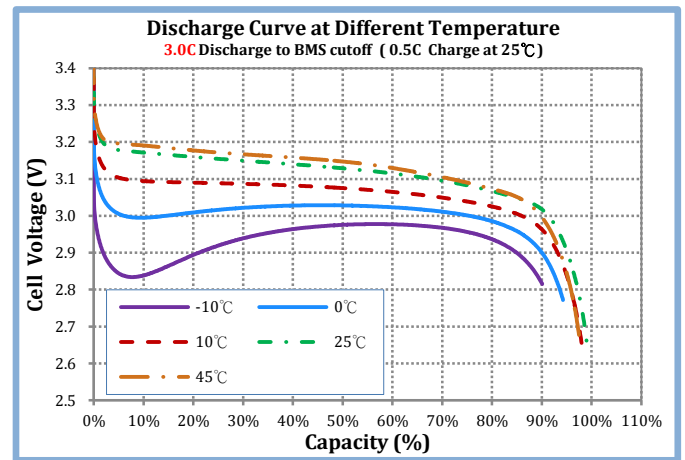
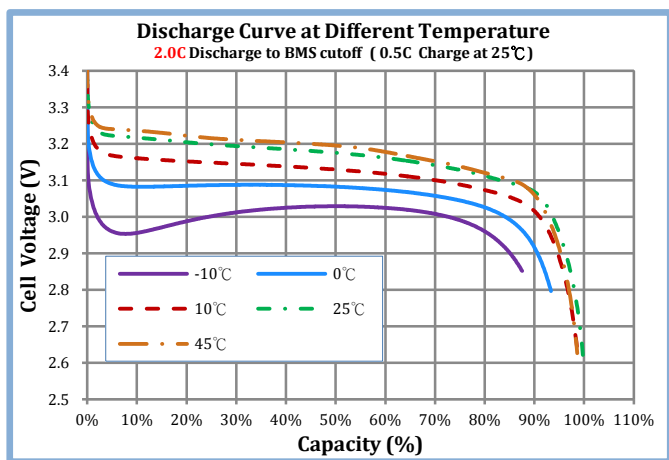
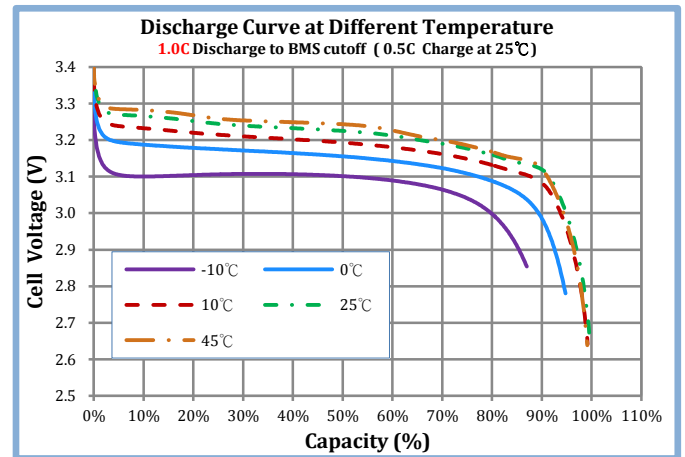
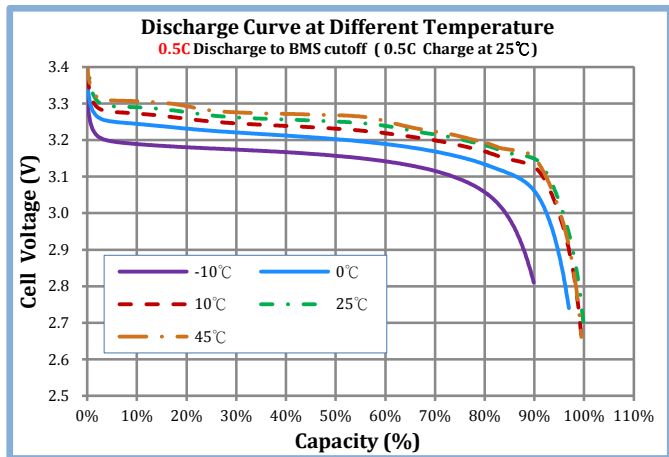

2. 充電特性 Rate Charge Curve

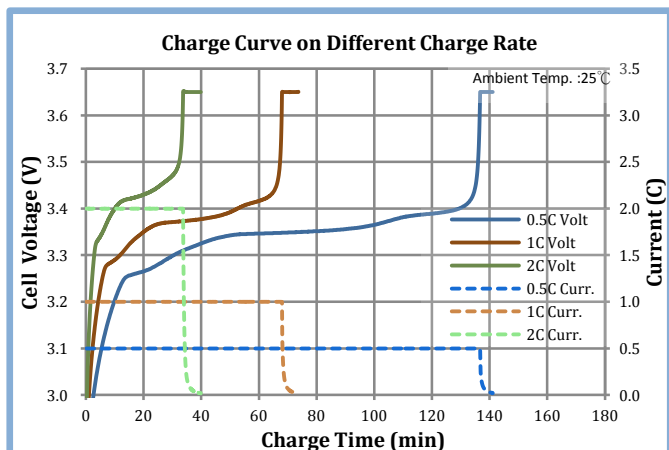

3. 循環壽命 Cycle Life

